

**METALURGICA PINTARELLI S.R.L.**

**Línea**

**Mercedes Benz**

**Descripción y Lista de Precios**

# INDICE

	Página
Extremos. Código. Nº original. Descripción.	1
Barra mando . Código . Nº original . Descripción.	2
Barra central. Código . Nº original . Descripción.	3
Barra intermedia. Código. Nº original. Descripción.	4
Tensor barra estabilizadora. Código. Nº original. Descripción.	5
Línea MAGIRUS-DEUTZ . DEUTZ . SCANIA.	6
Línea colectivo DEUTZ OA 101	7
Listado Código - Nº original.	8-9-10
L / LO 608 D . L 608 E	11
L 608 D (Importado)	12
L 312 . 3500 . 911	13
L / LK 1112 - 1114 . L 911 (dir.mecanica)	14
L / LK 1114 . LA 1114 (dir.hidraulica)	15
L 710 D . L 913 D	16
L / LO 812 - 813 - 814 D	17
L / LS 1928 - 1935 - 1938 - 1941 - 1945	18
L / LK 1514 - 1517 - 1518 - 1521	19
OC 1214 (freno hidráulico)	20
L 1615 - 1620 - 1622 - 1633 - 1720 . LK 1615 . LS 1622 - 1633	21
LO 1114 . L / S 1526 (freno volteo)	22
L / LK 1215	23
O - 140	24
O - 370 / 371 / 373 / 374 / 400	25
MB 180 D	26
OHL 1420 . OH 1419 (dir.hidraulica)	27
OH 1314 - 1318 - 1418 - 1419	28
O - 170	29
OHL 1316 - 1320 - 1420	30
OF 1214 (freno hidráulico)	31
OF 1214 (freno volteo) . OH 1418 - 1419	32
OH 1314 - 1315 - 1316 - 1318 - 1319 - 1320 . OH 1521 (freno volteo)	33
Conex. Barra estabilizadora OHL 1316 - 1320 - 1420	34
Tensor Barra estabilizadora L / LK 1517 - 1521 / 26 1215 al 1633 .L 1720	35
Tensor Barra estab. OC / OF 1214 (freno H) . OH 1314-15-16-19-20-1420	36
Tensor Barra estab. L / LK / LS 1620 - 1622 - 1633 mod. 96/97	37
Tensor Barra estab. 1214 K / 1418 K / 1714 K / 1718 K	38
Rotula MB 180 D.	39
Rotula Sprinter.	40
L 1615-20-22-33-1720 / LK 1615 / LS 1622-1633	41
OH-1621 L	42
L 710-912 Alemán	43
712 C / LO 914 electrónico	44
L / LK 1218 R - L 1418 - L / LK 1620	45
OH 1721 L (super bajo)	46
SCANIA K 112 / S 112	47
SCANIA K 112 / S 112	48
SCANIA K 112	49
SCANIA OMNIBUS K (susp. M.)	50
SCANIA conexión barra estabilizadora K 112	51
SCANIA R 113 - P 93 - R 143	52
M.Benz 1214 - 1218 - 1414 - 1418 - 1714 - 1718 (frontal)	53
M.Benz LO 809 - LO 813 - OF812 / 912 / 914	54
M.Benz OH 1721 L ( super bajo )	55

**METALURGICA PINTARELLI S.R.L.**

<b>EXTREMOS</b>				
Codigo	N° Original	Descripcion	Rosca	
56000	308.330.7335	L 608-LO 608 D-E B.CENTRAL	24x1.50	D
56001	308.330.7435	L 608-LO 608 D-E B.CENTRAL	24x1.50	I
56002		L 608 D Import. B.CENTRAL	22x1.50	D
56003		L 608 D Import. B.CENTRAL	22x1.50	I
56006	000.330.5035	L / LO 608 D-E B.MANDO	24x1.50	D
56007		L / LO 608 D-E B.MANDO	24x1.50	I
56008		312 - 911 - 3500 B.CENTRAL/MANDO	24x1.50	D
56009		312 - 911 - 3500 B.CENTRAL/MANDO	24x1.50	I
56010	688.330.0135	L / LS / LK 1112 - 1114 B.MANDO	24x1.50	D
		L / LS / LK 1112 - 1114 - 710 - 812 - 814 - 913 B.C.		
56011	688.330.0035	L / LS / LK 1112 - 1114 B.MANDO	24x1.50	I
		L / LS / LK 1112 - 1114 - 710 - 812 - 814 - 913 B.C.		
52020	350.330.7035	O-170 / LO 1114.L / LK 1215-1620-1622-1633	30x1.50	D
		OH1314 al OHL1621.OH/OHL 1419-1315-1320-1521		
56021	350.330.7135	O-170 / LO 1114.L / LK 1215-1620-1622-1633	30x1.50	I
		OH1314 al OHL1621.OH/OHL 1419-1315-1320-1521		
56040	344.330.7135	OC / OF 1214 - L / LK 1514-1517-1518-1521 fre.hidr	28x1.50	D
		710-812-913 B.MANDO		
56041	344.330.7235	OC / OF 1214 - L / LK 1514-1517-1518-1521 fre.hidr	28x1.50	I
58100	350.330.7235	L / LS 1928-1935-1938-1941-1945 B.C/M	30x1.50	D
		OH 1621 L B.MANDO		
58101	350.330.7335	L / LS 1928-1935-1938-1941-1945 B.C/M	30x1.50	I
		OH 1621 L B.MANDO		
56052		MB 180 D B.LATERAL	20x1.50	D
56053		MB 180 D B.LATERAL	20x1.50	I
56054		MB 180 D B.LARGA	18x1.50	D
56058		MB 180 D B.INTERMEDIA	54x1.50	D
56059		MB 180 D ROTULA		
56110		SPRINTER ROTULA		

**METALURGICA PINTARELLI S.R.L.**

BARRAS DE MANDO				
Codigo	N° Original	Descripcion	Largo (mm)	
			C/E	S/E
56004	308.460.7005	L / LO 608 D . L 608 E	493	410
56013	327.460.0005	L / LK 1112 - L 911 (dir.mec)	680	595
56014	321.460.1605	L / LK 1114 - LA 1114 (dir.hid)	620	540
56015		L 312 - 911 - 3500	385	295
56025	345.460.9605	LO 1114 - L / LS 1526 - 1514 (freno volante)	672	590
56030	345.460.8205	OF 1214 (freno volante).OH 1418-1419..1315	855	760
56033	345.460.8005	OH 1314-1318-1418 - 1419	832	730
56036	390.460.7005	OHL 1420 - OH 1419 (dir.hidr.)	806	710
56044	351.460.0305	L / LK 1514 - 1517 - 1518 - 1521	678	575
56046	344.460.7605	O - 170	750	662
56050	384.460.8805	L / LK 1215	768	680
56057	631.460.0705	MB 180 D	1230	1150
56062	345.460.8005	1521 (fr.volt) OH 1314-1315-1316-1318-1319-1320	832	750
56065	390.460.7005	OH / OHL 1316 - 1320 - 1420	806	700
56072	388.460.7605	L / LS 1928 - 1935 - 1938 - 1941- 1945	780	685
56075		O - 140	740	695
56078	345.460.7505	OC 1214 (fre.hidr)		
56080	688.460.7405	L 710 D - L 913 D	458	380
56082	688.460.0505	L / LO 812 - 813 - 814 D	458	370
56083	341.460.7705	OF 1214 (fre. hidraulico)	855	780
56085	364.460.7205	O - 370 - 371 - 373 - 374 - 400 Trasera	1002	905
56086	364.460.7305	O - 370 - 371 - 373 - 374 - 400 Delantera	915	810
56088	384.460.9205	L 1615-20-22-33-1720. LK 1615 . LS 1622 - 1633	775	680



**METALURGICA PINTARELLI S.R.L.**

<b>BARRA INTERMEDIA</b>				
<b>Codlgo</b>	<b>N° Original</b>	<b>Descripcion</b>	<b>Largo (mm)</b>	
			<b>C/E</b>	<b>S/E</b>
56027	345.460.0605	OH 1314-1315-1316-1318-1319-1320 . OH 1521 tv OHL 1420 - OH 1419 (dh) - OH 1314 / 18 - 1418 /19	655	570
56028	346.460.7405	OF 1214 (fren.volteo)/OH 1418 - 1419	460	370
56047	344.460.7405	O - 170	1160	1080
56055	631.330.0703	B.LATERAL MB 180 D	300	225
56056	631.330.0603	B INTERM. MB 180 D	670	590
56076		O - 140	1160	1080
56084	341.460.7805	OF 1214 (fren.hidr.)	460	375









**METALURGICA PINTARELLI S.R.L.**

Código Pintarelli	Numero Original Mercedes Benz
56000	308.330.7335
56001	308.330.7435
56002	
56003	
56006	000.330.5035
56007	
56008	
56009	
56010	688.330.0135
56011	688.330.0035
56020	350.330.7035
56021	350.330.7135
56040	344.330.7135
56041	344.330.7235
56052	
56053	
56054	
56058	
58100	350.330.7235
58101	350.330.7335

**METALURGICA PINTARELLI S.R.L.**

Código Pintarelli	Numero Original Mercedes Benz
56004	308.460.7005
56013	327.460.0005
56014	321.460.1605
56015	
56025	345.460.9605
56030	345.460.8205
56033	345.460.8005
56036	390.460.7005
56044	351.460.0305
56046	344.460.7605
56050	384.460.8805
56057	631.460.0705
56062	345.460.8005
56065	390.460.7005
56072	388.460.7605
56075	
56078	345.460.7505
56080	688.460.7405
56082	688.460.0505
56083	341.460.7705
56085	364.460.7205
56086	364.460.7305
56088	384.460.9205
56100	390.323.7068
56101	345.320.7389
56102	345.320.7189
56103	384.460.7389
56104	384.460.7589
56089	682.460.3205
56090	682.460.9805
56091	
56092	
56093	
56094	364.460.7405
56095	
56096	390.460.7305
56017	340.330.0903
56097	345.330.7303

**METALURGICA PINTARELLI S.R.L.**

Código Pintarelli	Numero Original Mercedes Benz
56027	345.460.0605
56028	346.460.7405
56047	344.460.7405
56055	631.330.0703
56056	631.330.0603
56076	
56084	341.460.7805
56005	308.330.7003
56012	327.330.0403
56016	
56022	345.330.7803
56045	345.330.7203
56048	364.330.7403
56073	350.330.7103
56077	
56079	344.330.7003
56081	688.330.0103

**METALURGICA PINTARELLI S.R.L.**

Mercedes Benz. L/LO 608 D -- L 608 E

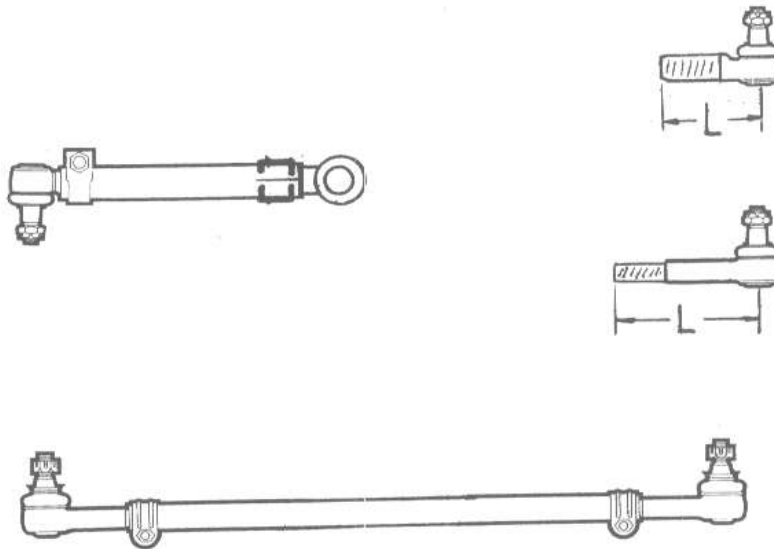

**EXTREMOS BARRA DE MANDO**

CODIGO	N° ORIGINAL	LARGO	ROSCA	SENTIDO
56006	308.330.7235	90 mm	24 X 1.50	DERECHO
56007		90 mm	24 X 1.50	IZQUIERDO

**EXTREMOS BARRA CENTRAL**

CODIGO	N° ORIGINAL	LARGO	ROSCA	SENTIDO
56000	308.330.7335	160 mm	24 x 1.50	DERECHO
56001	308.330.7435	160 mm	24 x 1.50	IZQUIERDO

**BARRA DE MANDO**

CODIGO	N° ORIGINAL	LARGO c/extr.	LARGO s/extr.
56004	308.460.7005	493 mm	410 mm

**BARRA CENTRAL**

CODIGO	N° ORIGINAL	LARGO c/extr.	LARGO s/extr.
56005	308.330.7003	1476 mm	1240 mm

**METALURGICA PINTARELLI S.R.L.**

Mercedes Benz. L 608 D . Importado.

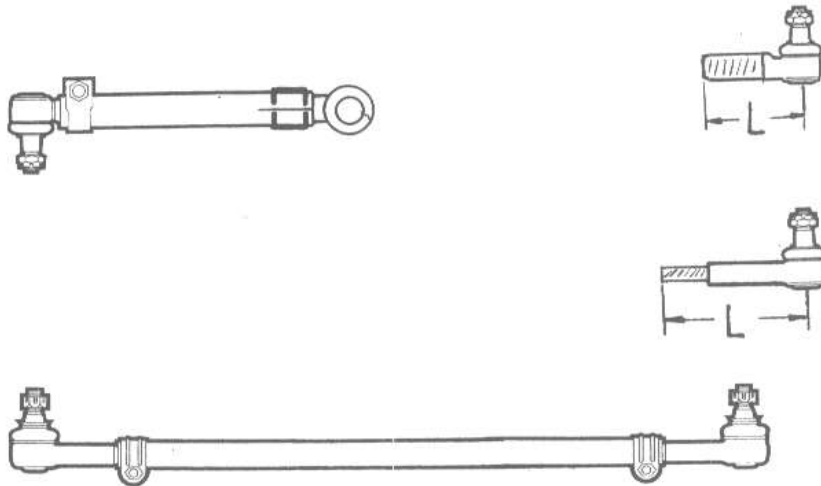

**EXTREMOS BARRA DE MANDO**

CODIGO	N° ORIGINAL	LARGO	ROSCA	SENTIDO
56006	308.330.7235	90 mm	24 x 1.50	DER
56007		90 mm	24 X 1.50	IZQ

**EXTREMOS BARRA CENTRAL**

CODIGO	N° ORIGINAL	LARGO	ROSCA	SENTIDO
56002 *		160 mm	22 x 1.50	DERECHO
56003 *		160 mm	22 x 1.50	IZQUIERDO

**BARRA DE MANDO**

CODIGO	N° ORIGINAL	LARGO c/extr.	LARGO s/extr.
56004	308.460.7005	493 mm	410 mm

**BARRA CENTRAL**

CODIGO	N° ORIGINAL	LARGO c/extr.	LARGO s/extr.
56005 *		1476 mm	1240 mm

**METALURGICA PINTARELLI S.R.L.**

Mercedes Benz. 3500 -- L 312 -- 911

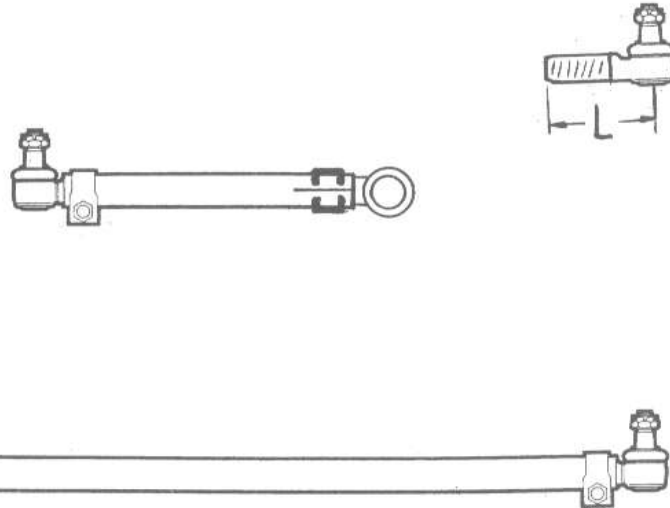

**EXTREMOS BARRA DE MANDO**

CODIGO	N° ORIGINAL	LARGO	ROSCA	SENTIDO
56008		105 mm	24 x 1.50	DER
56009		105 mm	24 x 1.50	IZQ

**EXTREMOS BARRA CENTRAL**

CODIGO	N° ORIGINAL	LARGO	ROSCA	SENTIDO
56008				
56009				

**BARRA DE MANDO**

CODIGO	N° ORIGINAL	LARGO c/extr.	LARGO s/extr.
56015		385 mm	295 mm

**BARRA CENTRAL**

CODIGO	N° ORIGINAL	LARGO c/extr.	LARGO s/extr.
56016		1480 mm	1400 mm

**METALURGICA PINTARELLI S.R.L.**

Mercedes Benz. L / LK 1112 . 1114. -- L 911 (dir.mecanica)

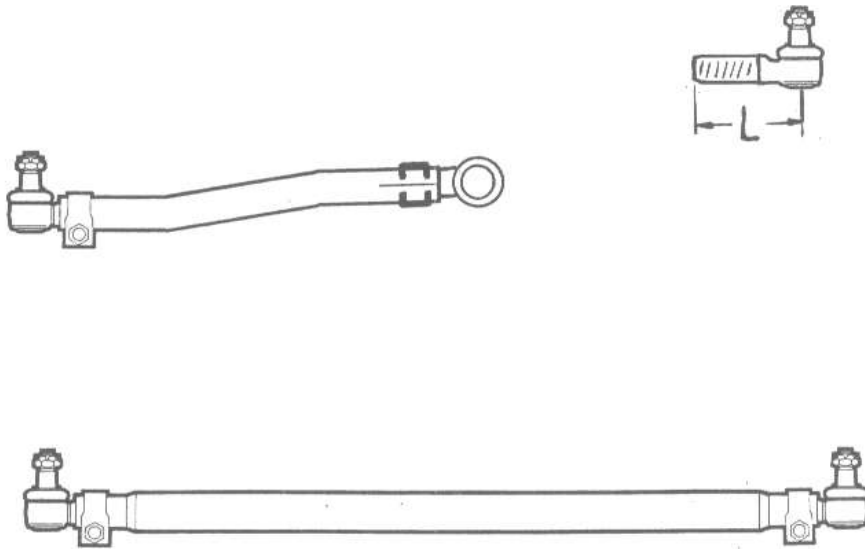

**EXTREMOS BARRA DE MANDO**

CODIGO	N° ORIGINAL	LARGO	ROSCA	SENTIDO
56010	688.330.0135	105 mm	24 x 1.50	DER
56011	688.330.0035	105 mm	24 x 1.50	IZQ

**EXTREMOS BARRA CENTRAL**

CODIGO	N° ORIGINAL	LARGO	ROSCA	SENTIDO
56010				
56011				

**BARRA DE MANDO**

CODIGO	N° ORIGINAL	LARGO c/extr.	LARGO s/extr.
56013	327.460.0005	680 mm	595 mm

**BARRA CENTRAL**

CODIGO	N° ORIGINAL	LARGO c/extr.	LARGO s/extr.
56012	327.330.0403	1648 mm	1570 mm



**METALURGICA PINTARELLI S.R.L.**

Mercedes Benz. L / LK 1114 -- LA 1114 (dir. hidraulica)

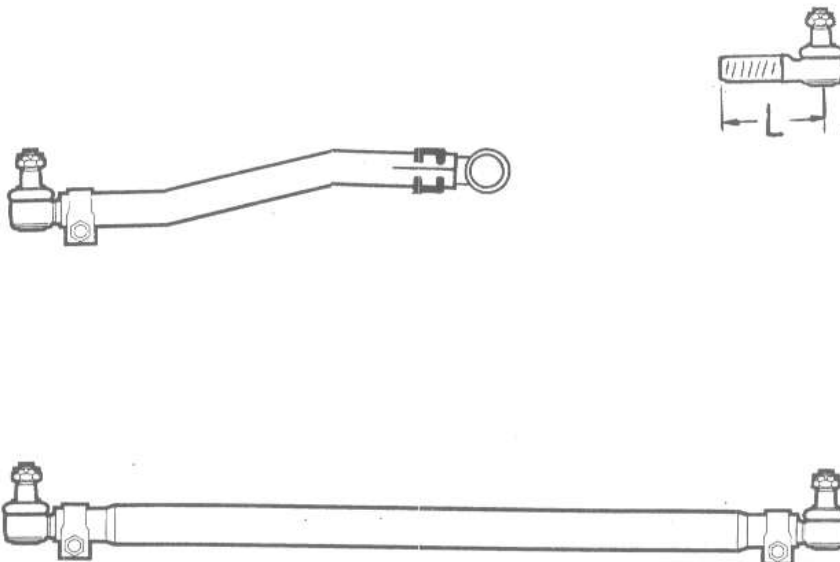

**EXTREMOS BARRA DE MANDO**

CODIGO	N° ORIGINAL	LARGO	ROSCA	SENTIDO
56010	688.330.0135	105 mm	24 x 1.50	DER
56011	688.330.0035	105 mm	24 x 1.50	IZQ

**EXTREMOS BARRA CENTRAL**

CODIGO	N° ORIGINAL	LARGO	ROSCA	SENTIDO
56010				
56011				

**BARRA DE MANDO**

CODIGO	N° ORIGINAL	LARGO c/extr.	LARGO s/extr.
56014	321.460.1605	620 mm	540 mm

**BARRA CENTRAL**

CODIGO	N° ORIGINAL	LARGO c/extr.	LARGO s/extr.
56012	327.330.0403	1648 mm	1570 mm

**METALURGICA PINTARELLI S.R.L.**

Mercedes Benz. L 710 D - L 913 D



**EXTREMOS BARRA DE MANDO**

CODIGO	N° ORIGINAL	LARGO	ROSCA	SENTIDO
56040	344.330.7135	105 mm	28 x 1.50	DER

**EXTREMOS BARRA CENTRAL**

CODIGO	N° ORIGINAL	LARGO	ROSCA	SENTIDO
56010	688.330.0135	105 mm	24 X 1.50	DER
56011	688.330.0035	105 mm	24 X 1.50	IZQ

**BARRA DE MANDO**

CODIGO	N° ORIGINAL	LARGO c/extr.	LARGO s/extr.
56080	688.460.7405	458 mm	380 mm

**BARRA CENTRAL**

CODIGO	N° ORIGINAL	LARGO c/extr.	LARGO s/extr.
56081	688.330.0103	1594 mm	1505 mm

**METALURGICA PINTARELLI S.R.L.**

Mercedes Benz. L / LO 812 - 813 - 814 D

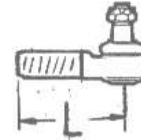

**EXTREMOS BARRA DE MANDO**

CODIGO	N° ORIGINAL	LARGO	ROSCA	SENTIDO
56040	344.330.7135	105 mm	28 x 1.50	DER
56041	344.330.7235	105 mm	28 x 1.50	IZQ

**EXTREMOS BARRA CENTRAL**

CODIGO	N° ORIGINAL	LARGO	ROSCA	SENTIDO
56010	688.330.0135	105 mm	24 X 1.50	DER
56011	688.330.0035	105 mm	24 X 1.50	IZQ

**BARRA DE MANDO**

CODIGO	N° ORIGINAL	LARGO c/extr.	LARGO s/extr.
56082	688.460.0505	458 mm	370 mm

**BARRA CENTRAL**

CODIGO	N° ORIGINAL	LARGO c/extr.	LARGO s/extr.
56081	688.330.0103	1594 mm	1505 mm

**METALURGICA PINTARELLI S.R.L.**

Mercedes Benz. L / LS 1928 -- 1935 -- 1938 -- 1941 -- 1945

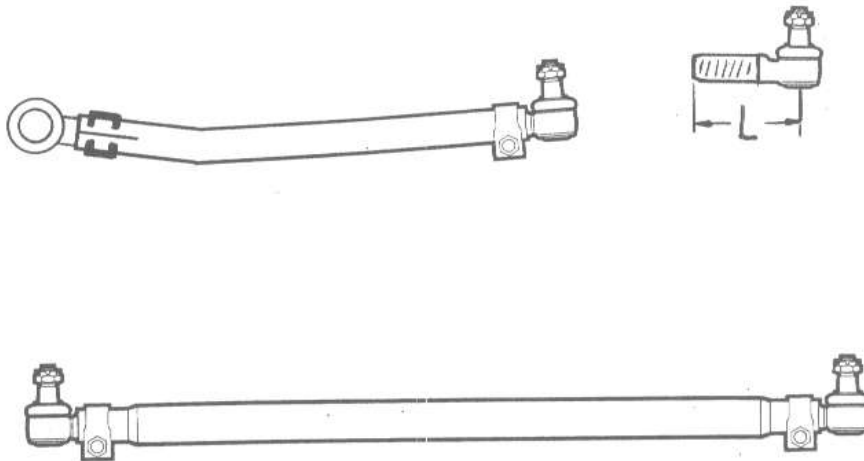

**EXTREMOS BARRA DE MANDO**

CODIGO	N° ORIGINAL	LARGO	ROSCA	SENTIDO
58100	350.330.7235	120 mm	30 x 1.50	DER
58101	350.330.7335	120 mm	30 x 1.50	IZQ

**EXTREMOS BARRA CENTRAL**

CODIGO	N° ORIGINAL	LARGO	ROSCA	SENTIDO
58100				
58101				

**BARRA DE MANDO**

CODIGO	N° ORIGINAL	LARGO c/extr.	LARGO s/extr.
56072	388.460.7605	780 mm	685 mm

**BARRA CENTRAL**

CODIGO	N° ORIGINAL	LARGO c/extr.	LARGO s/extr.
56073	350.330.7103	1620 mm	1520 mm

**METALURGICA PINTARELLI S.R.L.**

Mercedes Benz. L / LK 1514 -- 1517 -- 1518 -- 1521

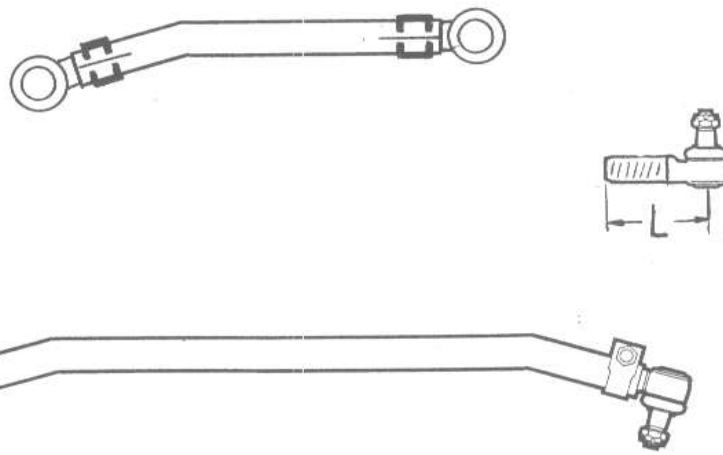

**EXTREMOS BARRA DE MANDO**

CODIGO	N° ORIGINAL	LARGO	ROSCA	SENTIDO
56040	344.330.7135	105 mm	28 x 1.50	DER
56041	344.330.7235	105 mm	28 x 1.50	IZQ

**EXTREMOS BARRA CENTRAL**

CODIGO	N° ORIGINAL	LARGO	ROSCA	SENTIDO
56040				
56041				

**BARRA DE MANDO**

CODIGO	N° ORIGINAL	LARGO c/extr.	LARGO s/extr.
56044	351.460.0305	678 mm	575 mm

**BARRA CENTRAL**

CODIGO	N° ORIGINAL	LARGO c/extr.	LARGO s/extr.
56045	345.330.7203	1648 mm	1570 mm

**TENSOR BARRA ESTABILIZADORA**

CODIGO	No. ORIGINAL	LARGO
56101	345.320.7389	260 mm

**METALURGICA PINTARELLI S.R.L.**

Mercedes Benz. OC 1214 (Freno Hidraulico)

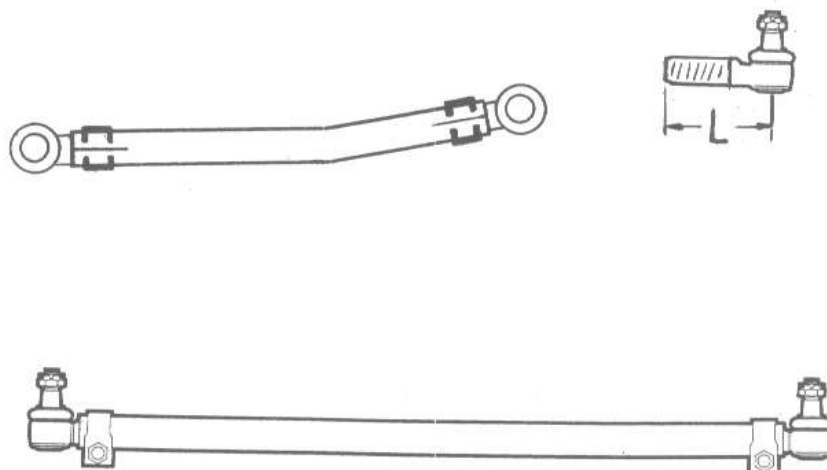

**EXTREMOS BARRA DE MANDO**

CODIGO	N° ORIGINAL	LARGO	ROSCA	SENTIDO
56040	344.330.7135	105 mm	28 x 1.50	DER
56041	344.330.7235	105 mm	28 x 1.50	IZQ

**EXTREMOS BARRA CENTRAL**

CODIGO	N° ORIGINAL	LARGO	ROSCA	SENTIDO
56040				
56041				

**BARRA DE MANDO**

CODIGO	N° ORIGINAL	LARGO c/extr.	LARGO s/extr.
56078	345.460.7505	mm	mm

**BARRA CENTRAL**

CODIGO	N° ORIGINAL	LARGO c/extr.	LARGO s/extr.
56079	344.330.7003	1648 mm	1565 mm

**TENSOR BARRA ESTABILIZADORA**

CODIGO	No. ORIGINAL	LARGO
56101	345.320.7389	260 mm

**METALURGICA PINTARELLI S.R.L.**

Mercedes Benz. L 1615 - 1620 - 1622 - 1633 - 1720

LK 1615 / LS 1622 - 1633

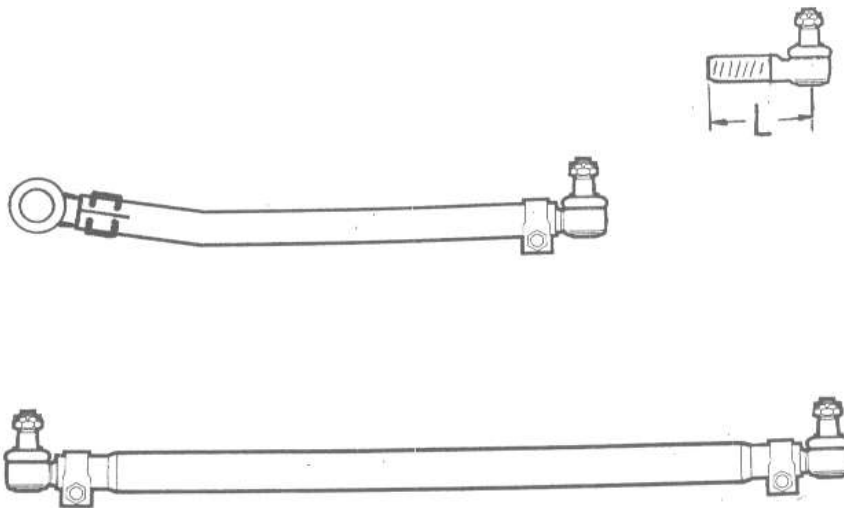

**EXTREMOS BARRA DE MANDO**

CODIGO	N° ORIGINAL	LARGO	ROSCA	SENTIDO
56020	350.330.7035	120 mm	30 x 1.50	DER
56021	350.330.7135	120 mm	30 X 1.50	IZQ

**EXTREMOS BARRA CENTRAL**

CODIGO	N° ORIGINAL	LARGO	ROSCA	SENTIDO
56020				
56021				

**BARRA DE MANDO**

CODIGO	N° ORIGINAL	LARGO c/extr.	LARGO s/extr.
56098	384.460.9205	775 mm	680 mm

**BARRA CENTRAL**

CODIGO	N° ORIGINAL	LARGO c/extr.	LARGO s/extr.
56022	345.330.7403	1611 mm	1520 mm

**TENSOR BARRA ESTABILIZADORA**

CODIGO	No. ORIGINAL	LARGO
56101	345.320.7389	260 mm

**METALURGICA PINTARELLI S.R.L.**

Mercedes Benz. LO 1114 -- L / S 1526 (Freno Volteo )

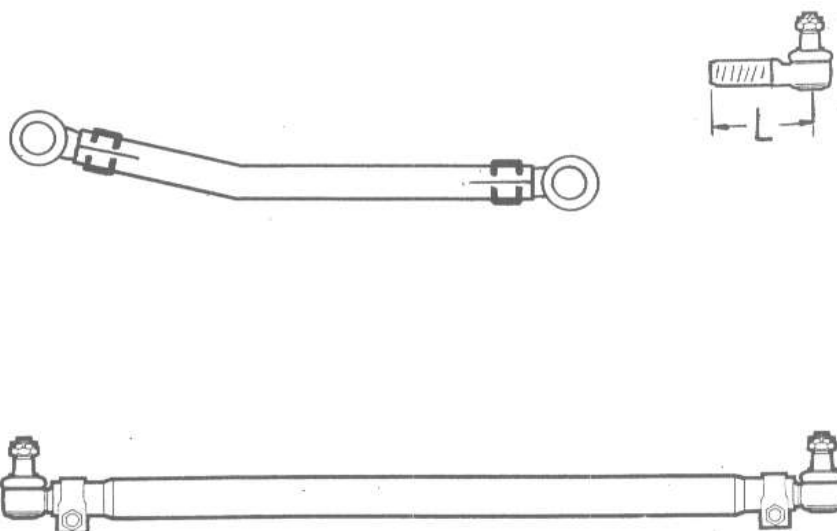

**EXTREMOS BARRA DE MANDO**

CODIGO	N° ORIGINAL	LARGO	ROSCA	SENTIDO
56020	350.330.7035	120 mm	30 x 1.50	DER
56021	350.330.7135	120 mm	30 x 1.50	IZQ

**EXTREMOS BARRA CENTRAL**

CODIGO	N° ORIGINAL	LARGO	ROSCA	SENTIDO
56020				
56021				

**BARRA DE MANDO**

CODIGO	N° ORIGINAL	LARGO c/extr.	LARGO s/extr.
56025	345.460.9605	672 mm	590 mm

**BARRA CENTRAL**

CODIGO	N° ORIGINAL	LARGO c/extr.	LARGO s/extr.
56022	345.330.7403	1611 mm	1520 mm

**TENSOR BARRA ESTABILIZADORA**

CODIGO	No. ORIGINAL	LARGO
56101	345.320.7389	260 mm



**METALURGICA PINTARELLI S.R.L.**

Mercedes Benz. L / LK 1215

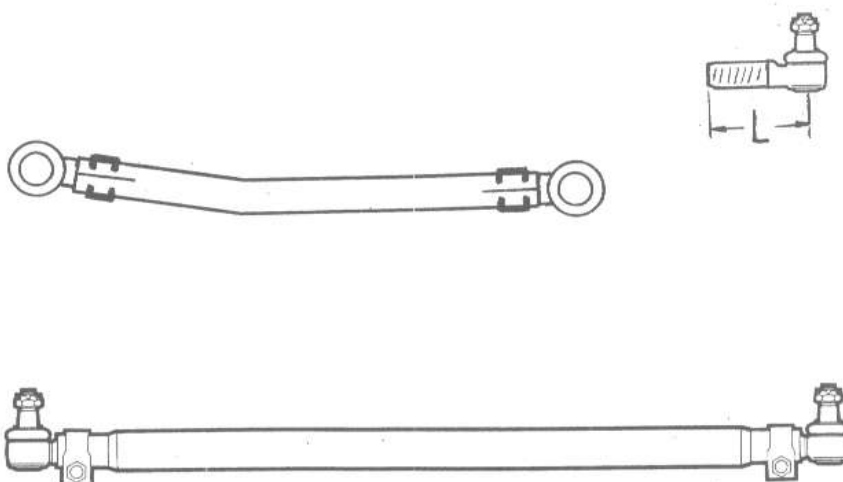

**EXTREMOS BARRA DE MANDO**

CODIGO	N° ORIGINAL	LARGO	ROSCA	SENTIDO
56020	350.330.7035	120 mm	30 x 1.50	DER
56021	350.330.7135	120 mm	30 x 1.50	IZQ

**EXTREMOS BARRA CENTRAL**

CODIGO	N° ORIGINAL	LARGO	ROSCA	SENTIDO
56020				
56021				

**BARRA DE MANDO**

CODIGO	N° ORIGINAL	LARGO c/extr.	LARGO s/extr.
56050	384.460.8805	768 mm	680 mm

**BARRA CENTRAL**

CODIGO	N° ORIGINAL	LARGO c/extr.	LARGO s/extr.
56022	345.330.7403	1611 mm	1520 mm

**TENSOR BARRA ESTABILIZADORA**

CODIGO	No. ORIGINAL	LARGO
56102	345.320.7189	310 mm

**METALURGICA PINTARELLI S.R.L.**

Mercedes Benz . O -- 140

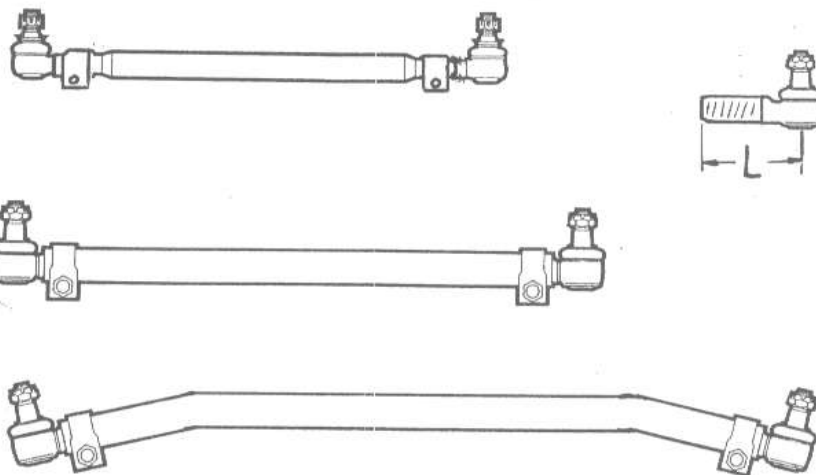

**EXTREMOS BARRA DE MANDO**

CODIGO	N° ORIGINAL	LARGO	ROSCA	SENTIDO
56010	688.330.0135	105 mm	24 x 1.50	DER
56011	688.330.0035	105 mm	24 x 1.50	IZQ

**EXTREMOS BARRA CENTRAL**

CODIGO	N° ORIGINAL	LARGO	ROSCA	SENTIDO
56040	344.330.7135	105 mm	28 x 1.50	DER
56041	344.330.7235	105 mm	28 x 1.50	IZQ

**EXTREMOS BARRA INTERMEDIA**

CODIGO	N° ORIGINAL	LARGO	ROSCA	SENTIDO
56010				
56011				

**BARRA DE MANDO**

CODIGO	N° ORIGINAL	LARGO c/extr.	LARGO s/extr.
56075		740 mm	695 mm

**BARRA CENTRAL**

CODIGO	N° ORIGINAL	LARGO c/extr.	LARGO s/extr.
56077		1530 mm	1525 mm

**BARRA INTERMEDIA**

CODIGO	N° ORIGINAL	LARGO c/extr.	LARGO s/extr.
56076		1160 mm	1080 mm

**METALURGICA PINTARELLI S.R.L.**

Mercedes Benz . O - 370 / 371 / 373 / 374 / 400

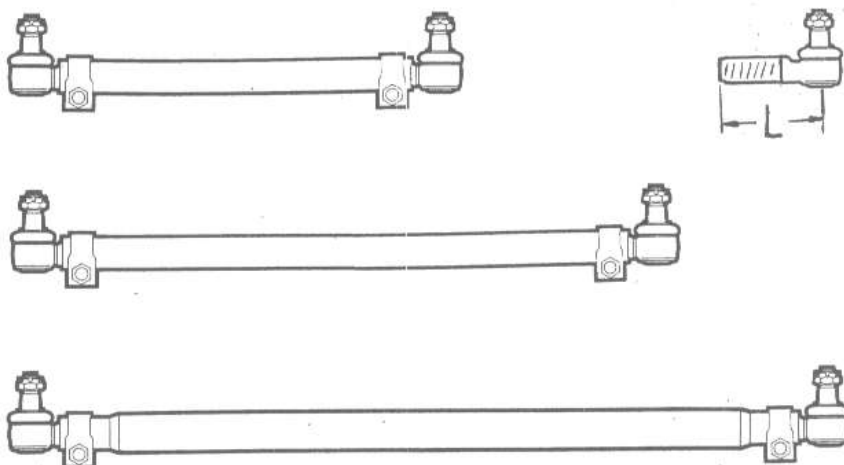

**EXTREMOS BARRA DELANTERA**

CODIGO	N° ORIGINAL	LARGO	ROSCA	SENTIDO
56020	350.330.7035	120 mm	30 x 1.50	DER
56021	350.330.7135	120 mm	30 x 1.50	IZQ

**EXTREMOS BARRA CENTRAL**

CODIGO	N° ORIGINAL	LARGO	ROSCA	SENTIDO
56020				
56021				

**EXTREMOS BARRA TRASERA**

CODIGO	N° ORIGINAL	LARGO	ROSCA	SENTIDO
56020				
56021				

**BARRA DELANTERA**

CODIGO	N° ORIGINAL	LARGO c/extr.	LARGO s/extr.
56086	364.460.7305	915 mm	810 mm

**BARRA CENTRAL (reforma)**

CODIGO	N° ORIGINAL	LARGO c/extr.	LARGO s/extr.
56022	345.330.7903.	1611 mm	1520 mm

**BARRA TRASERA**

CODIGO	N° ORIGINAL	LARGO c/extr.	LARGO s/extr.
56085	364.460.7205	1002 mm	905 mm

**METALURGICA PINTARELLI S.R.L.**

Mercedes Benz . MB 180 D

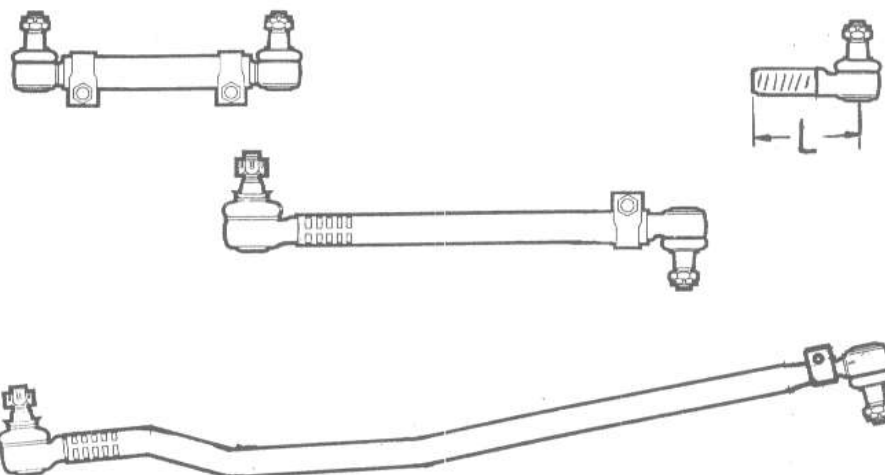

**EXTREMOS BARRA DE MANDO**

CODIGO	N° ORIGINAL	LARGO	ROSCA	SENTIDO
56054		95 mm	18 x 1.50	DER

**EXTREMOS BARRA LATERAL**

CODIGO	N° ORIGINAL	LARGO	ROSCA	SENTIDO
56052		95 mm	20 X 1.50	DER
56053		95 mm	20 X 1.50	IZQ

**EXTREMOS BARRA INTERMEDIA**

CODIGO	N° ORIGINAL	LARGO	ROSCA	SENTIDO
56058		105 mm	24 X 1.50	DER

**BARRA DE MANDO**

CODIGO	N° ORIGINAL	LARGO c/extr.	LARGO s/extr.
56057	631.460.0705	1230 mm	1150 mm

**BARRA LATERAL**

CODIGO	N° ORIGINAL	LARGO c/extr.	LARGO s/extr.
56055	631.330.0703	300 mm	225 mm

**BARRA INTERMEDIA**

CODIGO	N° ORIGINAL	LARGO c/extr.	LARGO s/extr.
56056	631.330.0603	670 mm	590 mm

**METALURGICA PINTARELLI S.R.L.**

Mercedes Benz . OHL 1420 - OH 1419 Dir. HID.

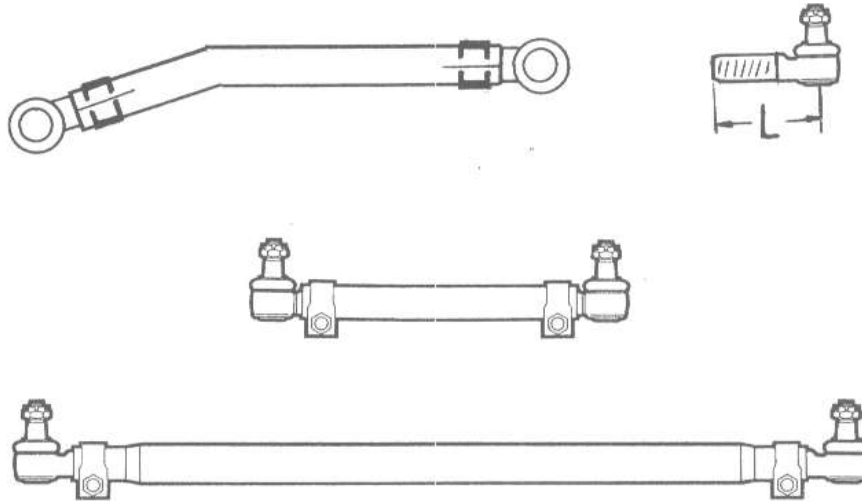

**EXTREMOS BARRA DE MANDO**

CODIGO	N° ORIGINAL	LARGO	ROSCA	SENTIDO
56020	350.330.7035	120 mm	30 x 1.50	DER
56021	350.330.7135	120 mm	30 x 1.50	IZQ

**EXTREMOS BARRA CENTRAL**

CODIGO	N° ORIGINAL	LARGO	ROSCA	SENTIDO
56020				
56021				

**EXTREMOS BARRA INTERMEDIA**

CODIGO	N° ORIGINAL	LARGO	ROSCA	SENTIDO
56020				
56021				

**BARRA DE MANDO**

CODIGO	N° ORIGINAL	LARGO c/extr.	LARGO s/extr.
56036	390.460.7005	806 mm	710 mm

**BARRA CENTRAL**

CODIGO	N° ORIGINAL	LARGO c/extr.	LARGO s/extr.
56022	345.330.7403.	1611 mm	1520 mm

**BARRA INTERMEDIA**

CODIGO	N° ORIGINAL	LARGO c/extr.	LARGO s/extr.
56027	345.460.0605	655 mm	570 mm

**METALURGICA PINTARELLI S.R.L.**

Mercedes Benz . OH 1314 - 1318 - 1418 - 1419

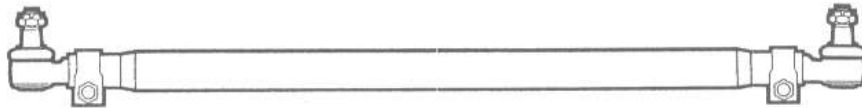
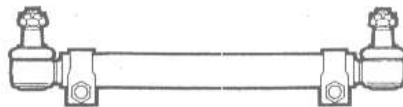
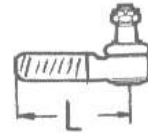

**EXTREMOS BARRA DE MANDO**

CODIGO	N° ORIGINAL	LARGO	ROSCA	SENTIDO
56020	350.330.7035	120 mm	30 x 1.50	DER
56021	350.330.7135	120 mm	30 x 1.50	IZQ

**EXTREMOS BARRA CENTRAL**

CODIGO	N° ORIGINAL	LARGO	ROSCA	SENTIDO
56020				
56021				

**EXTREMOS BARRA INTERMEDIA**

CODIGO	N° ORIGINAL	LARGO	ROSCA	SENTIDO
56020				
56021				

**BARRA DE MANDO**

CODIGO	N° ORIGINAL	LARGO c/extr.	LARGO s/extr.
56033	345.460.8005	832 mm	730 mm

**BARRA CENTRAL**

CODIGO	N° ORIGINAL	LARGO c/extr.	LARGO s/extr.
56022	345.330.7403	1611 mm	1520 mm

**BARRA INTERMEDIA**

CODIGO	N° ORIGINAL	LARGO c/extr.	LARGO s/extr.
56027	345.460.0605	655 mm	570 mm

**METALURGICA PINTARELLI S.R.L.**

Mercedes Benz . O --170

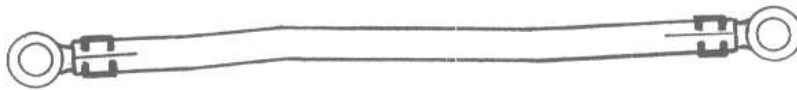
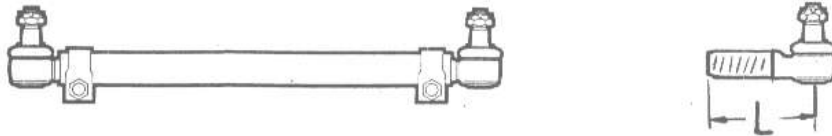

**EXTREMOS BARRA DE MANDO**

CODIGO	N° ORIGINAL	LARGO	ROSCA	SENTIDO
56020	350.330.7035	120 mm	30 x 1.50	DER
56021	350.330.7135	120 mm	30 x 1.50	IZQ

**EXTREMOS BARRA CENTRAL**

CODIGO	N° ORIGINAL	LARGO	ROSCA	SENTIDO
56020				
56021				

**EXTREMOS BARRA INTERMEDIA**

CODIGO	N° ORIGINAL	LARGO	ROSCA	SENTIDO
56020				
56021				

**BARRA DE MANDO**

CODIGO	N° ORIGINAL	LARGO c/extr.	LARGO s/extr.
56046	344.460.7605	750 mm	662 mm

**BARRA CENTRAL**

CODIGO	N° ORIGINAL	LARGO c/extr.	LARGO s/extr.
56048	364.330.7403	1600 mm	1520 mm

**BARRA INTERMEDIA**

CODIGO	N° ORIGINAL	LARGO c/extr.	LARGO s/extr.
56047	344.460.7405	1160 mm	1080 mm

**METALURGICA PINTARELLI S.R.L.**

Mercedes Benz . OHL 1316 - 1320 - 1420

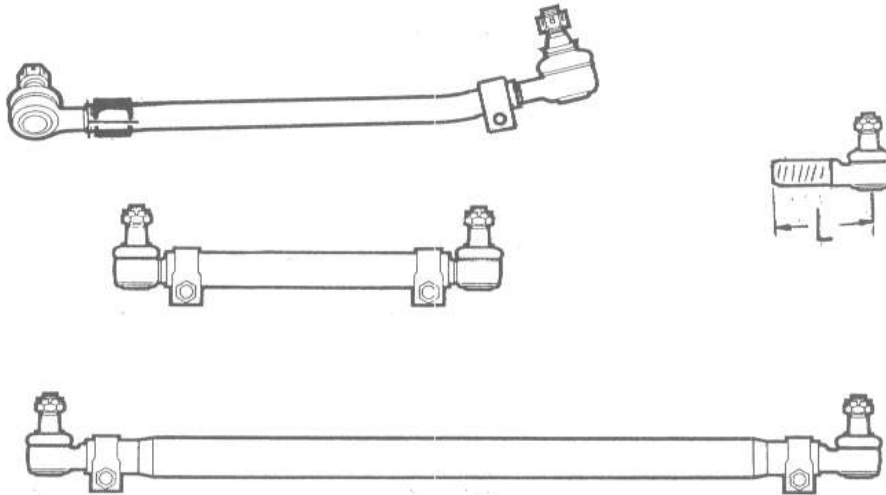

**EXTREMOS BARRA DE MANDO**

CODIGO	N° ORIGINAL	LARGO	ROSCA	SENTIDO
56020	350.330.7035	120 mm	30 x 1.50	DER
56021	350.330.7135	120 mm	30 x 1.50	IZQ

**EXTREMOS BARRA CENTRAL**

CODIGO	N° ORIGINAL	LARGO	ROSCA	SENTIDO
56020				
56021				

**EXTREMOS BARRA INTERMEDIA**

CODIGO	N° ORIGINAL	LARGO	ROSCA	SENTIDO
56020				
56021				

**BARRA DE MANDO**

CODIGO	N° ORIGINAL	LARGO c/extr.	LARGO s/extr.
56065	390.460.7005	806 mm	700 mm

**BARRA CENTRAL**

CODIGO	N° ORIGINAL	LARGO c/extr.	LARGO s/extr.
56022	345.330.7403.	1611 mm	1520 mm

**BARRA INTERMEDIA**

CODIGO	N° ORIGINAL	LARGO c/extr.	LARGO s/extr.
56027	345.460.0605	655 mm	570 mm

**TENSOR BARRA ESTABILIZADORA**

CODIGO	No. ORIGINAL	LARGO
56102	345.320.7189	310 mm



**METALURGICA PINTARELLI S.R.L.**

Mercedes Benz . OF 1214 (Freno Hidraulico)

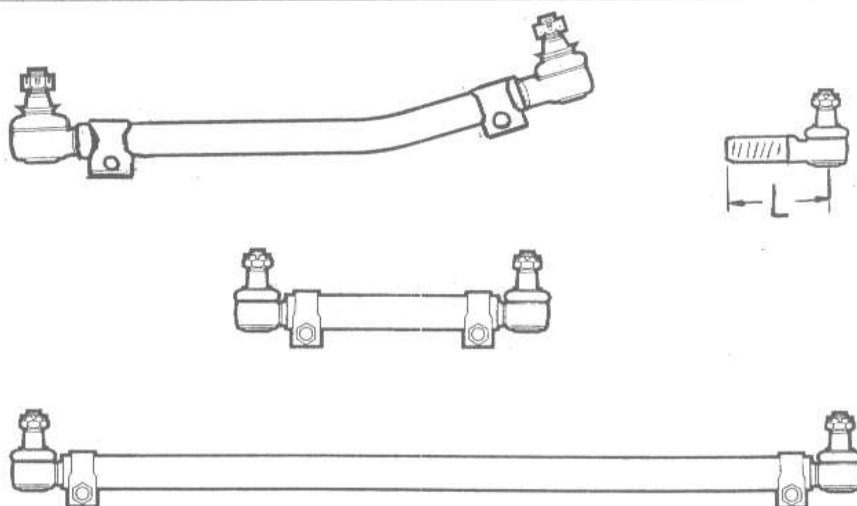

**EXTREMOS BARRA DE MANDO**

CODIGO	N° ORIGINAL	LARGO	ROSCA	SENTIDO
56040	344.330.7135	105 mm	28 x 1.50	DER
56041	344.330.7235	105 mm	28 x 1.50	IZQ

**EXTREMOS BARRA CENTRAL**

CODIGO	N° ORIGINAL	LARGO	ROSCA	SENTIDO
56040				
56041				

**EXTREMOS BARRA INTERMEDIA**

CODIGO	N° ORIGINAL	LARGO	ROSCA	SENTIDO
56040				
56041				

**BARRA DE MANDO**

CODIGO	N° ORIGINAL	LARGO c/extr.	LARGO s/extr.
56083	341.460.7705	855 mm	780 mm

**BARRA CENTRAL**

CODIGO	N° ORIGINAL	LARGO c/extr.	LARGO s/extr.
56079	344.330.7003	1648 mm	1650 mm

**BARRA INTERMEDIA**

CODIGO	N° ORIGINAL	LARGO c/extr.	LARGO s/extr.
56084	341.460.7805	460 mm	375 mm

**TENSOR BARRA ESTABILIZADORA**

CODIGO	No. ORIGINAL	LARGO
56102	345.320.7189	310 mm

**METALURGICA PINTARELLI S.R.L.**

Mercedes Benz . OF 1214 (freno volteo) - OH 1418 - 1419

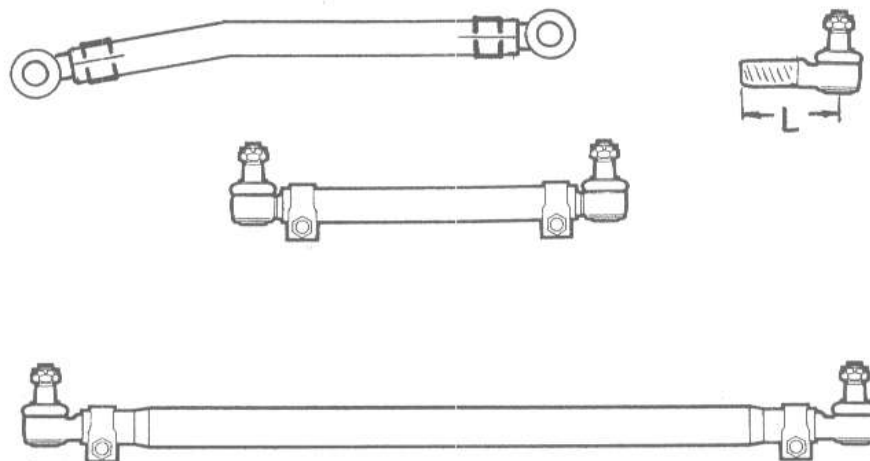

**EXTREMOS BARRA DE MANDO**

CODIGO	N° ORIGINAL	LARGO	ROSCA	SENTIDO
56020	350.330.7035	120 mm	30 x 1.50	DER
56021	350.330.7135	120 mm	30 x 1.50	IZQ

**EXTREMOS BARRA CENTRAL**

CODIGO	N° ORIGINAL	LARGO	ROSCA	SENTIDO
56020				
56021				

**EXTREMOS BARRA INTERMEDIA**

CODIGO	N° ORIGINAL	LARGO	ROSCA	SENTIDO
56020				
56021				

**BARRA DE MANDO**

CODIGO	N° ORIGINAL	LARGO c/extr.	LARGO s/extr.
56030	345.460.8205	855 mm	760 mm

**BARRA CENTRAL**

CODIGO	N° ORIGINAL	LARGO c/extr.	LARGO s/extr.
56022	345.330.7403.	1611 mm	1520 mm

**BARRA INTERMEDIA**

CODIGO	N° ORIGINAL	LARGO c/extr.	LARGO s/extr.
56028	346.460.7405	460 mm	370 mm

**TENSOR BARRA ESTABILIZADORA**

CODIGO	No. ORIGINAL	LARGO
56102	345.320.7189	310 mm

**METALURGICA PINTARELLI S.R.L.**

Mercedes Benz . OH 1314 - 1315 - 1316 - 1318 - 1319 - 1320  
OH 1521 (Freno volante)

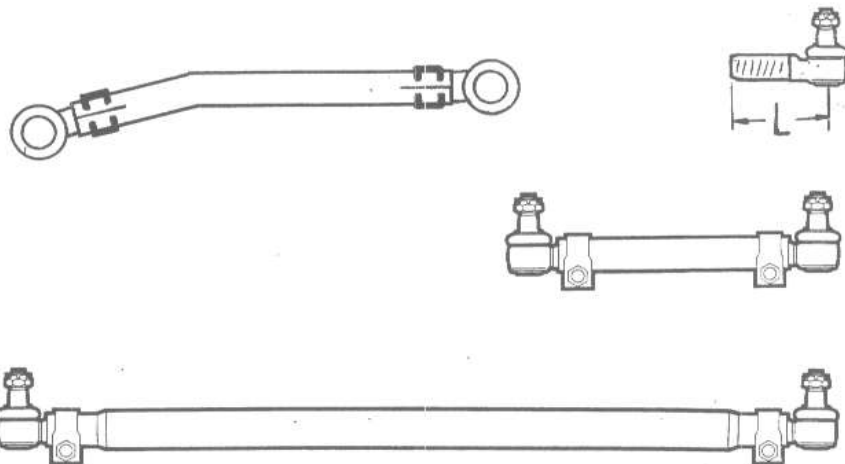

**EXTREMOS BARRA DE MANDO**

CODIGO	N° ORIGINAL	LARGO	ROSCA	SENTIDO
56020	350.330.7035	120 mm	30 x 1.50	DER
56021	350.330.7135	120 mm	30 x 1.50	IZQ

**EXTREMOS BARRA CENTRAL**

CODIGO	N° ORIGINAL	LARGO	ROSCA	SENTIDO
56020				
56021				

**EXTREMOS BARRA INTERMEDIA**

CODIGO	N° ORIGINAL	LARGO	ROSCA	SENTIDO
56020				
56021				

**BARRA DE MANDO**

CODIGO	N° ORIGINAL	LARGO c/extr.	LARGO s/extr.
56062	345.460.8005	832 mm	750 mm

**BARRA CENTRAL**

CODIGO	N° ORIGINAL	LARGO c/extr.	LARGO s/extr.
56022	345.330.7403.	1611 mm	1520 mm

**BARRA INTERMEDIA**

CODIGO	N° ORIGINAL	LARGO c/extr.	LARGO s/extr.
56027	345.460.0605	655 mm	570 mm

**TENSOR BARRA ESTABILIZADORA**

CODIGO	No. ORIGINAL	LARGO
56102	345.320.7189	310 mm

**METALURGICA PINTARELLI S.R.L.**

Mercedes Benz . Conexión barra estabilizadora  
OHL1316 - 1320 - 1420

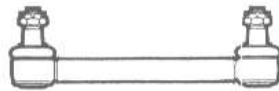
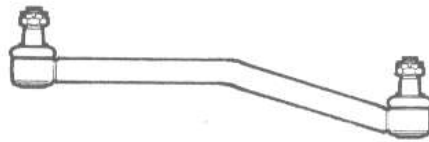

<i>CODIGO</i>	<i>No. ORIGINAL</i>	<i>LARGO</i>
<b>56100 DEL</b>	<b>390.323.7068</b>	<b>330 mm</b>
<b>56087 TRAS.</b>	<b>390.323.7168</b>	<b>280 mm</b>

**METALURGICA PINTARELLI S.R.L.**

Mercedes Benz . Tensor barra estabilizadora  
L / LK 1517 - 1521 / 26 - 1215 al 1633 / L 1720

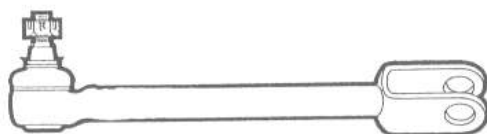

<i>CODIGO</i>	<i>No. ORIGINAL</i>	<i>LARGO</i>
56101	345.320.7389	260 mm

**METALURGICA PINTARELLI S.R.L.**

Mercedes Benz . Tensor barra estabilizadora  
OC / OF 1214 (f.h).OH 1314 - 15 - 16 - 19 - 20 - 1420

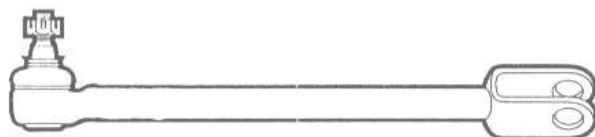

<i>CODIGO</i>	<i>No. ORIGINAL</i>	<i>LARGO</i>
<b>56102</b>	<b>345.320.7189</b>	<b>310 mm</b>

**METALURGICA PINTARELLI S.R.L.**

Mercedes Benz . Tensor barra estabilizadora  
L / LK / LS 1620 / 1622 / 1633 mod 96/97

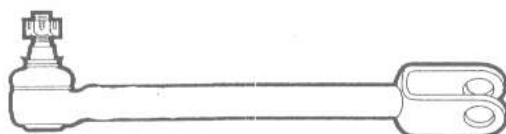

<i>CODIGO</i>	<i>No. ORIGINAL</i>	<i>LARGO</i>
<b>56103</b>	<b>384.460.7589</b>	<b>260 mm</b>

**METALURGICA PINTARELLI S.R.L.**

Mercedes Benz . Tensor barra estabilizadora  
1214 K / 1418 K / 1714 K / 1718 K

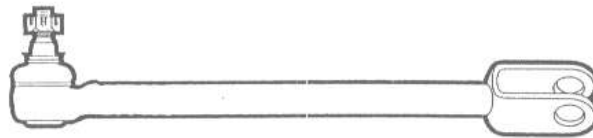

<i>CODIGO</i>	<i>No. ORIGINAL</i>	<i>LARGO</i>
<b>56104</b>	<b>384.460.7389</b>	<b>310 mm</b>



**METALURGICA PINTARELLI S.R.L.**

Mercedes Benz.

Rotula M B 180 D.

Cod 56059

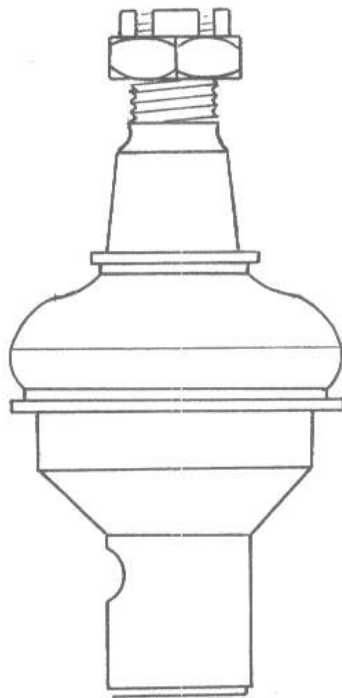

**METALURGICA PINTARELLI S.R.L.**

Mercedes Benz.

Rotula Sprinter.

Cod. 56110

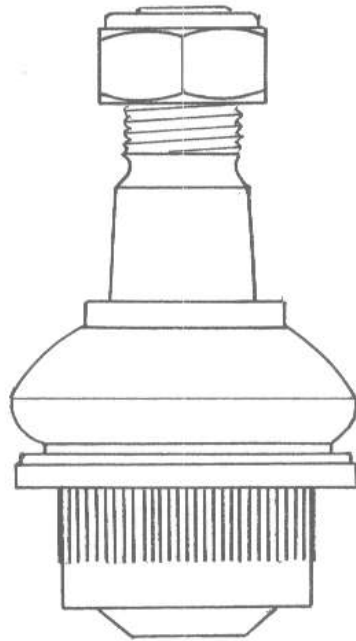

**METALURGICA PINTARELLI S.R.L.**

Mercedes Benz. L 1615-20-22-33-1720 / LK1615  
LS1622-1633

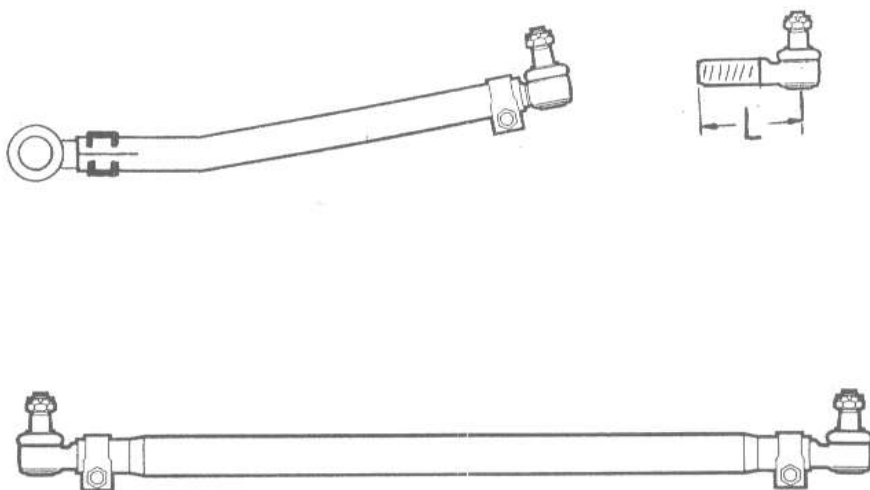

**EXTREMOS BARRA DE MANDO**

CODIGO	N° ORIGINAL	LARGO	ROSCA	SENTIDO
56020	350.330.7035	120 mm	30 x 1.50	DER
56021	350.330.7135	120 mm	30 x 1.50	IZQ

**EXTREMOS BARRA CENTRAL**

CODIGO	N° ORIGINAL	LARGO	ROSCA	SENTIDO
56020				
56021				

**BARRA DE MANDO**

CODIGO	N° ORIGINAL	LARGO c/extr.	LARGO s/extr.
56088	384.460.9205	775 mm	685 mm

**BARRA CENTRAL**

CODIGO	N° ORIGINAL	LARGO c/extr.	LARGO s/extr.
56022	345.330.7403	1611 mm	1520 mm

**TENSOR BARRA ESTABILIZADORA**

CODIGO	No. ORIGINAL	LARGO
56101	345.320.7389	260 mm

**METALURGICA PINTARELLI S.R.L.**

Mercedes Benz. OH - 1621 L

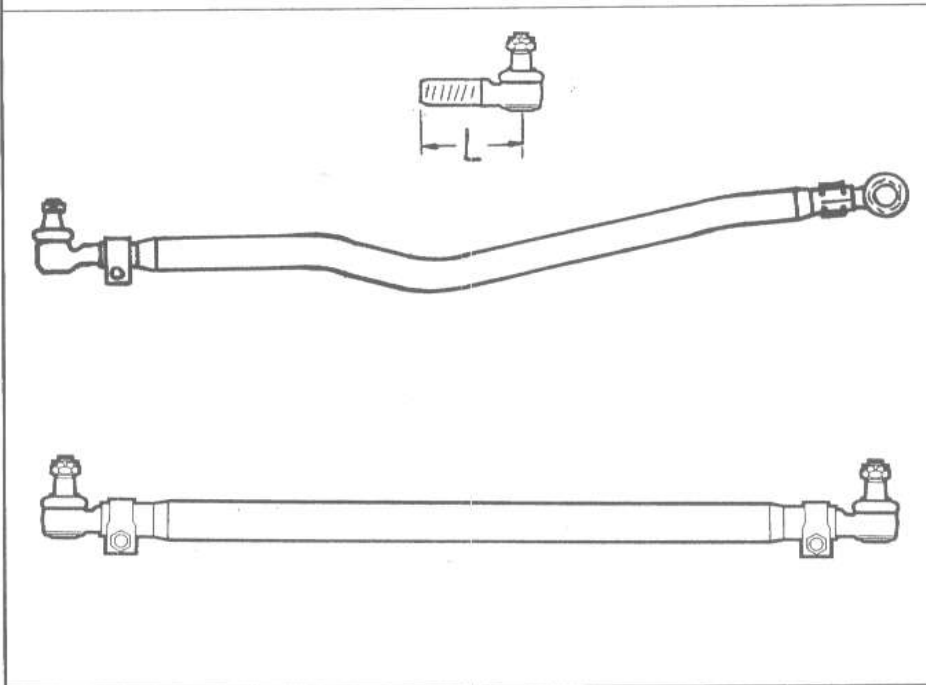

**EXTREMOS BARRA DE MANDO**

CODIGO	N° ORIGINAL	LARGO	ROSCA	SENTIDO
58100	350.330.7235	120 mm	30 X 1.50	DER
58101	350.330.7335	120 mm	30 X 1.50	IZQ

**EXTREMOS BARRA CENTRAL**

CODIGO	N° ORIGINAL	LARGO	ROSCA	SENTIDO
56106		120 mm	30 X 1.50	DER
56107		120 mm	30 X 1.50	IZQ

**BARRA DE MANDO**

CODIGO	N° ORIGINAL	LARGO c/extr.	LARGO s/extr.
56096	390.460.7305	1225 mm	1125 mm

**BARRA CENTRAL**

CODIGO	N° ORIGINAL	LARGO c/extr.	LARGO s/extr.
56097	000.330.0603	1770 mm	1670 mm

**METALURGICA PINTARELLI S.R.L.**

Mercedes Benz. L 710 - 912 Alemán

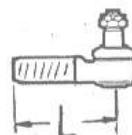
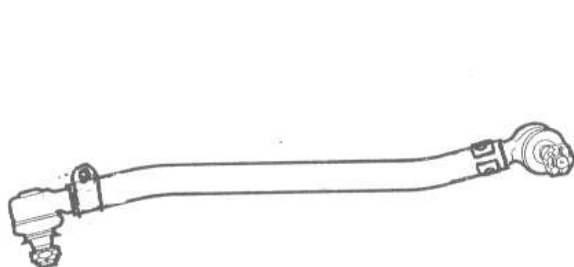

**EXTREMOS BARRA DE MANDO**

CODIGO	N° ORIGINAL	LARGO	ROSCA	SENTIDO
56006	308.330.7235	90 mm	24 x 1.50	DER
56007		90 mm	24 x 1.50	IZQ

**EXTREMOS BARRA CENTRAL**

CODIGO	N° ORIGINAL	LARGO	ROSCA	SENTIDO

**BARRA DE MANDO**

CODIGO	N° ORIGINAL	LARGO c/extr.	LARGO s/extr.
56095		493 mm	420 mm

**BARRA CENTRAL**

CODIGO	N° ORIGINAL	LARGO c/extr.	LARGO s/extr.

**METALURGICA PINTARELLI S.R.L.**

Mercedes Benz. 712 C - LO 914 electrónico

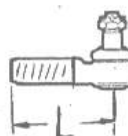

**EXTREMOS BARRA DE MANDO**

CODIGO	N° ORIGINAL	LARGO	ROSCA	SENTIDO
56090		120 mm	30 x 1.50	DER
56091		120 mm	30 x 1.50	IZQ

**EXTREMOS BARRA CENTRAL**

CODIGO	N° ORIGINAL	LARGO	ROSCA	SENTIDO

**BARRA DE MANDO**

CODIGO	N° ORIGINAL	LARGO c/extr.	LARGO s/extr.
56093	688.460.8305	930 mm	830 mm

**BARRA CENTRAL**

CODIGO	N° ORIGINAL	LARGO c/extr.	LARGO s/extr.

**METALURGICA PINTARELLI S.R.L.**

Mercedes Benz. L - LK 1218 R --L 1418 - L / LK 1620

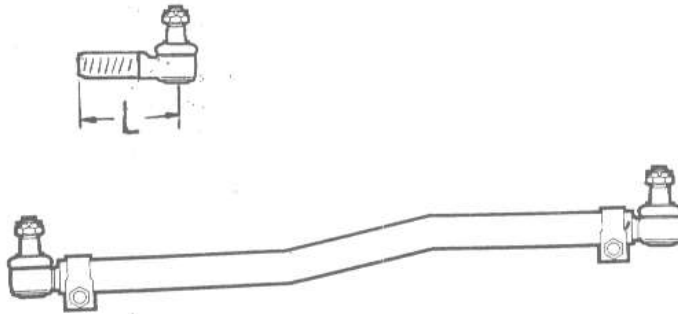

**EXTREMOS BARRA DE MANDO**

CODIGO	N° ORIGINAL	LARGO	ROSCA	SENTIDO
58100	350.330.7235	120 mm	30 x 1.50	DER
58101	350.330.7335	120 mm	30 x 1.50	IZQ

**EXTREMOS BARRA CENTRAL**

CODIGO	N° ORIGINAL	LARGO	ROSCA	SENTIDO

**BARRA DE MANDO**

CODIGO	N° ORIGINAL	LARGO c/extr.	LARGO s/extr.
56098	695.460.7005	880 mm	77.5 mm

**BARRA CENTRAL**

CODIGO	N° ORIGINAL	LARGO c/extr.	LARGO s/extr.

**METALURGICA PINTARELLI S.R.L.**

Mercedes Benz. OH - 1721 L (super bajo)

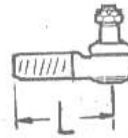

**EXTREMOS BARRA DE MANDO**

CODIGO	N° ORIGINAL	LARGO	ROSCA	SENTIDO
58100	350.330.7235	120 mm	30 X 1.50	DER
58101	350.330.7335	120 mm	30 X 1.50	IZQ

**EXTREMOS BARRA CENTRAL**

CODIGO	N° ORIGINAL	LARGO	ROSCA	SENTIDO
56120	001.330.9135	190 mm	1 1/4 X 12	DER
56121	001.330.9035	190 mm	1 1/4 X 12	IZQ

**BARRA DE MANDO**

CODIGO	N° ORIGINAL	LARGO c/extr.	LARGO s/extr.
56122	390.460.7405	1020 mm	925 mm

**BARRA CENTRAL**

CODIGO	N° ORIGINAL	LARGO c/extr.	LARGO s/extr.
56123	000.330.0803	1750 mm	1650 mm



**METALURGICA PINTARELLI S.R.L.**

**SCANIA K 112 / S 112**

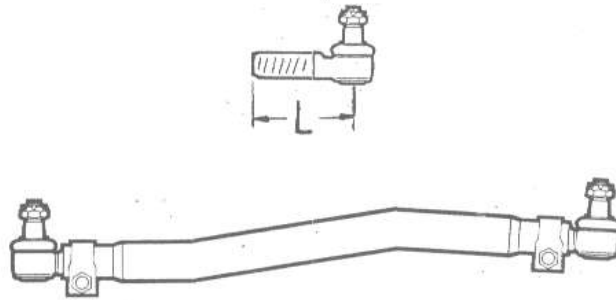

**EXTREMOS BARRA DE MANDO**

CODIGO	N° ORIGINAL	LARGO	ROSCA	SENTIDO
58100	350.330.7235	120 mm	30 X 1.50	DER
58101	350.330.7335	120 mm	30 X 1.50	IZQ

**EXTREMOS BARRA CENTRAL**

CODIGO	N° ORIGINAL	LARGO	ROSCA	SENTIDO

**BARRA DE MANDO**

CODIGO	N° ORIGINAL	LARGO c/extr.	LARGO s/extr.
58102	415.400	1015 mm	915 mm

**BARRA CENTRAL**

CODIGO	N° ORIGINAL	LARGO c/extr.	LARGO s/extr.

**METALURGICA PINTARELLI S.R.L.**

**SCANIA K 112 / S 112**

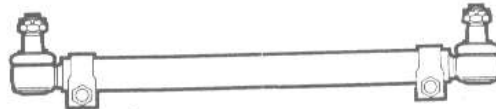

**EXTREMOS BARRA DE MANDO**

CODIGO	N° ORIGINAL	LARGO	ROSCA	SENTIDO
58100	350.330.7235	120 mm	30 X 1.50	DER
58101	350.330.7335	120 mm	30 X 1.50	IZQ

**EXTREMOS BARRA CENTRAL**

CODIGO	N° ORIGINAL	LARGO	ROSCA	SENTIDO

**BARRA DE MANDO**

CODIGO	N° ORIGINAL	LARGO c/extr.	LARGO s/extr.
58103	439.340	853 mm	753 mm

**BARRA CENTRAL**

CODIGO	N° ORIGINAL	LARGO c/extr.	LARGO s/extr.

**METALURGICA PINTARELLI S.R.L.**

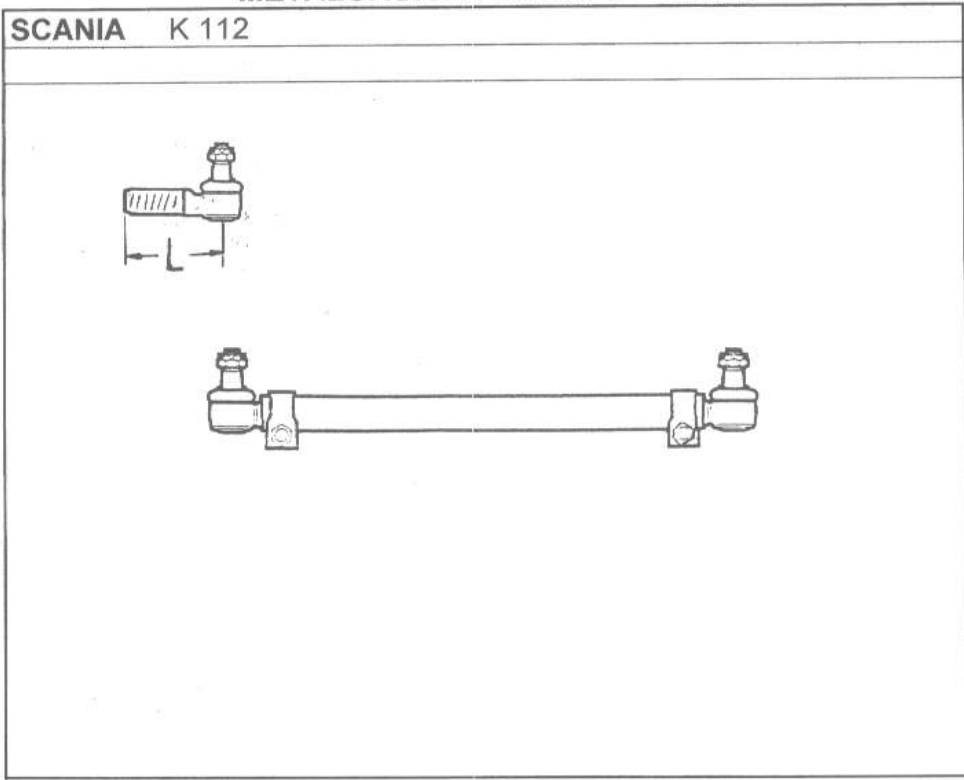

**EXTREMOS BARRA DE MANDO**

CODIGO	N° ORIGINAL	LARGO	ROSCA	SENTIDO
58100	350.330.7235	120 mm	30 X 1.50	DER
58101	350.330.7335	120 mm	30 X 1.50	IZQ

**EXTREMOS BARRA CENTRAL**

CODIGO	N° ORIGINAL	LARGO	ROSCA	SENTIDO

**BARRA DE MANDO**

CODIGO	N° ORIGINAL	LARGO c/extr.	LARGO s/extr.
58104	524.362	830 mm	730 mm

**BARRA CENTRAL**

CODIGO	N° ORIGINAL	LARGO c/extr.	LARGO s/extr.

**METALURGICA PINTARELLI S.R.L.**

**SCANIA OMNIBUS K (suspensión m)**

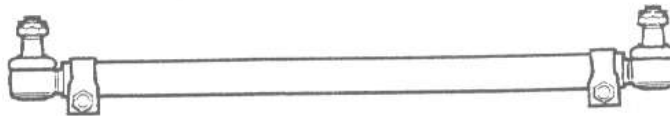
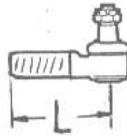

**EXTREMOS BARRA DE MANDO**

CODIGO	N° ORIGINAL	LARGO	ROSCA	SENTIDO
58100	350.330.7235	120 mm	30 X 1.50	DER
58101	350.330.7335	120 mm	30 X 1.50	IZQ

**EXTREMOS BARRA CENTRAL**

CODIGO	N° ORIGINAL	LARGO	ROSCA	SENTIDO

**BARRA DE MANDO**

CODIGO	N° ORIGINAL	LARGO c/extr.	LARGO s/extr.
58105	1675825	931 mm	820 mm

**BARRA CENTRAL**

CODIGO	N° ORIGINAL	LARGO c/extr.	LARGO s/extr.



<i>CODIGO</i>	<i>No. ORIGINAL</i>	<i>LARGO</i>
<b>58108</b>	<b>416159</b>	<b>210 mm</b>

**METALURGICA PINTARELLI S.R.L.**

**SCANIA R 113 - P 93 - R 143**

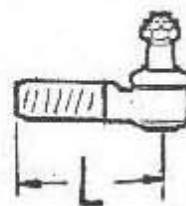

**EXTREMOS BARRA DE MANDO**

CODIGO	N° ORIGINAL	LARGO	ROSCA	SENTIDO
58100		120 mm	30 x 1.50	DER
58107		140 mm	30 x 1.50	IZQ

**EXTREMOS BARRA CENTRAL**

CODIGO	N° ORIGINAL	LARGO	ROSCA	SENTIDO

**BARRA DE MANDO**

CODIGO	N° ORIGINAL	LARGO c/extr.	LARGO s/extr.
58106	1369919	940 mm	815 mm

**BARRA CENTRAL**

CODIGO	N° ORIGINAL	LARGO c/extr.	LARGO s/extr.

**METALURGICA PINTARELLI S.R.L.**

Mercedes Benz 1214 - 1218 - 1414 - 1418 - 1714 - 1718

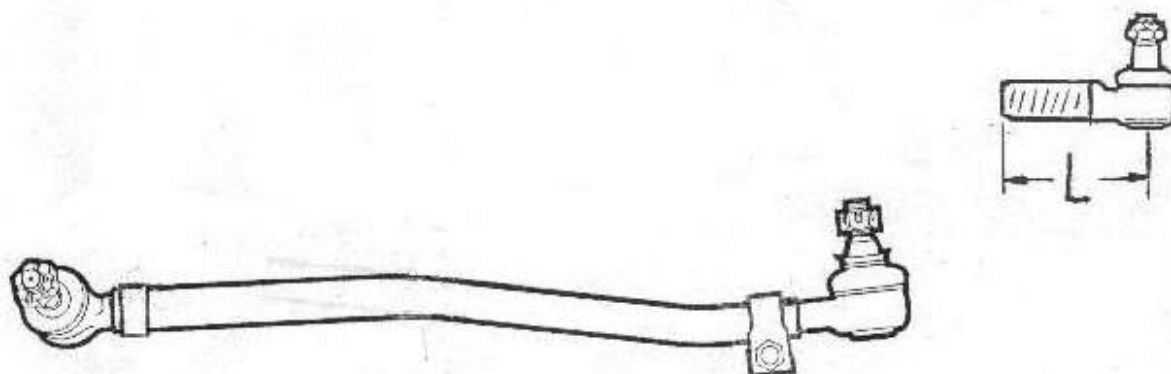

**EXTREMOS BARRA DE MANDO**

CODIGO	N° ORIGINAL	LARGO	ROSCA	SENTIDO
<b>58100</b>		<b>120 mm</b>	<b>30 X 1.50</b>	<b>DER</b>
<b>58101</b>		<b>120 mm</b>	<b>30 X 1.50</b>	<b>IZQ</b>

**EXTREMOS BARRA CENTRAL**

CODIGO	N° ORIGINAL	LARGO	ROSCA	SENTIDO

**BARRA DE MANDO**

CODIGO	N° ORIGINAL	LARGO c/extr.	LARGO s/extr.
<b>56132</b>		<b>977 mm</b>	<b>887 mm</b>

**BARRA CENTRAL**

CODIGO	N° ORIGINAL	LARGO c/extr.	LARGO s/extr.

**METALURGICA PINTARELLI S.R.L.**

Mercedes Benz LO 809 - LO 813 - OF 812 / 912 / 914

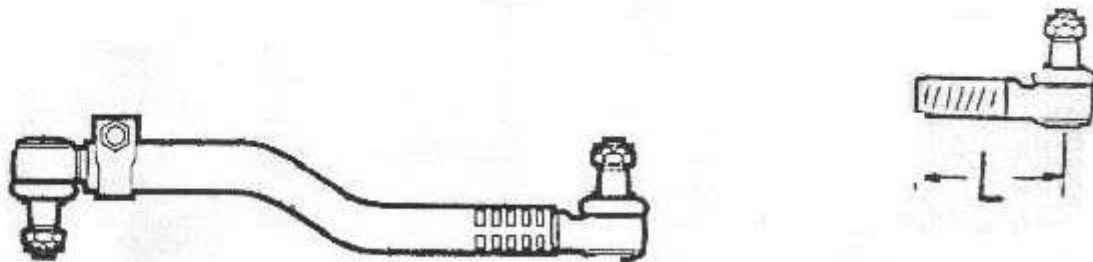

**EXTREMOS BARRA DE MANDO**

CODIGO	N° ORIGINAL	LARGO	ROSCA	SENTIDO
<b>56040</b>		<b>105 mm</b>	<b>28 X 1.50</b>	<b>DER</b>

**EXTREMOS BARRA CENTRAL**

CODIGO	N° ORIGINAL	LARGO	ROSCA	SENTIDO

**BARRA DE MANDO**

CODIGO	N° ORIGINAL	LARGO c/extr.	LARGO s/extr.
<b>56130</b>		<b>515 mm</b>	

**BARRA CENTRAL**

CODIGO	N° ORIGINAL	LARGO c/extr.	LARGO s/extr.



# METALURGICA PINTARELLI S.R.L.

Mercedes Benz. OH - 1721 L (super bajo)

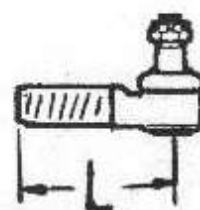

## EXTREMOS BARRA DE MANDO

CODIGO	N° ORIGINAL	LARGO	ROSCA	SENTIDO
58100		120 mm	30 X 1.50	DER
58101		120 mm	30 X 1.50	IZQ

## EXTREMOS BARRA CENTRAL

CODIGO	N° ORIGINAL	LARGO	ROSCA	SENTIDO
56120	001.330.9135	200 mm	1 ¼ x 12	DER
56121	001.330.9035	200 mm	1 ¼ x 12	IZQ

## BARRA DE MANDO

CODIGO	N° ORIGINAL	LARGO c/extr.	LARGO s/extr.
56122	390.460.7405	1020 mm	925 mm

## BARRA CENTRAL

CODIGO	N° ORIGINAL	LARGO c/extr.	LARGO s/extr.
56123	000.330.0803	1750 mm	1650 mm